

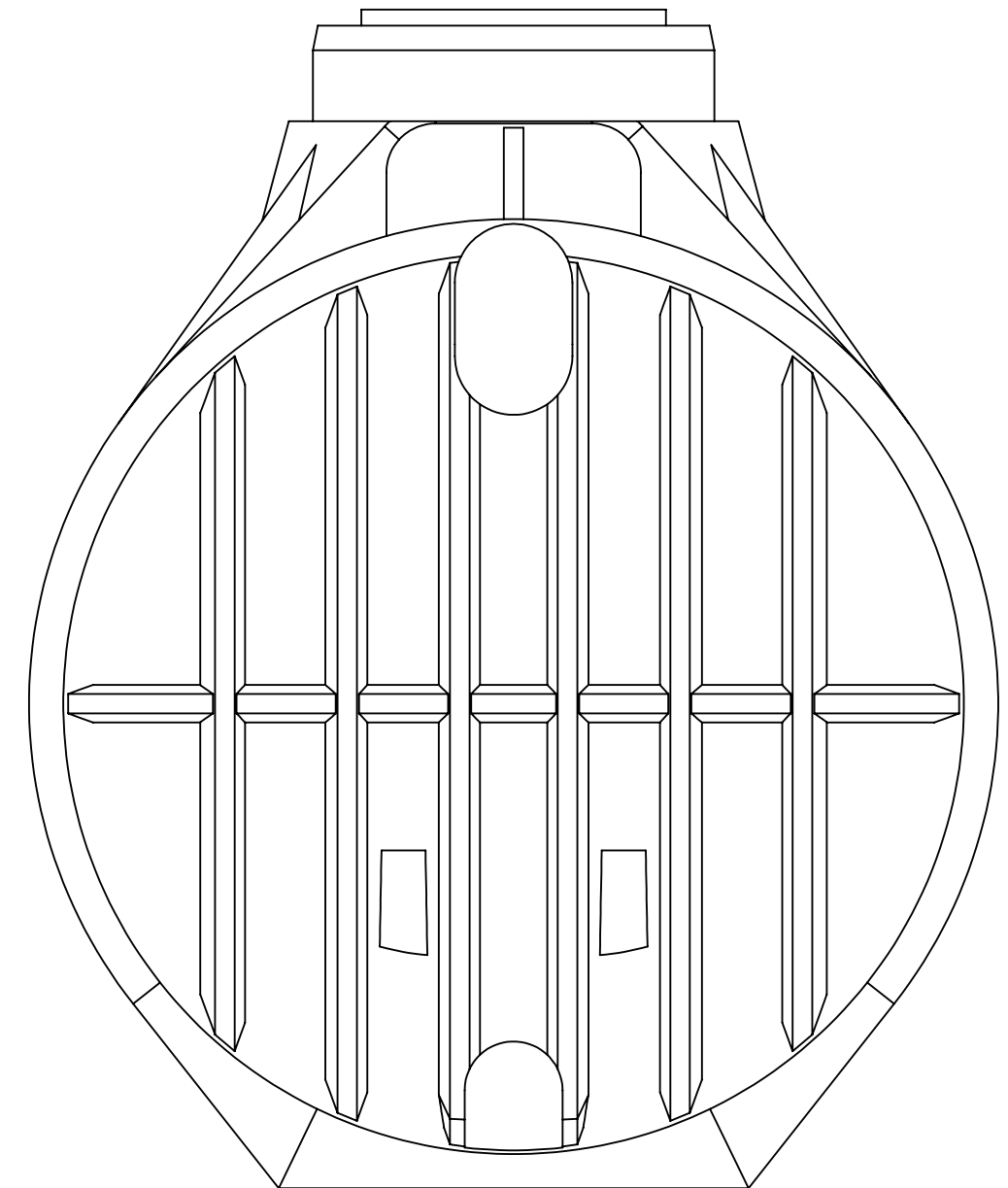

Stücklistentabelle					
Pos	Standard/ MENGE	Bauteil Nr.	Benennung	Revisionsstand	Material
1	1	35.4900.0000	Atlantis 5300L ohne Trennwand	002	LLDPE
2	1	65.0000.0001	Adapterring	000	PE
3	4	74.5000.0670	Holzschraube Seko A2 4x20-z	000	A2

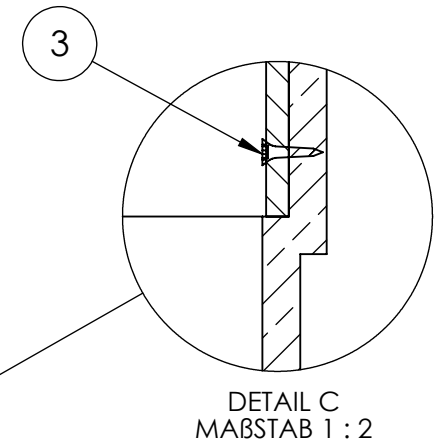
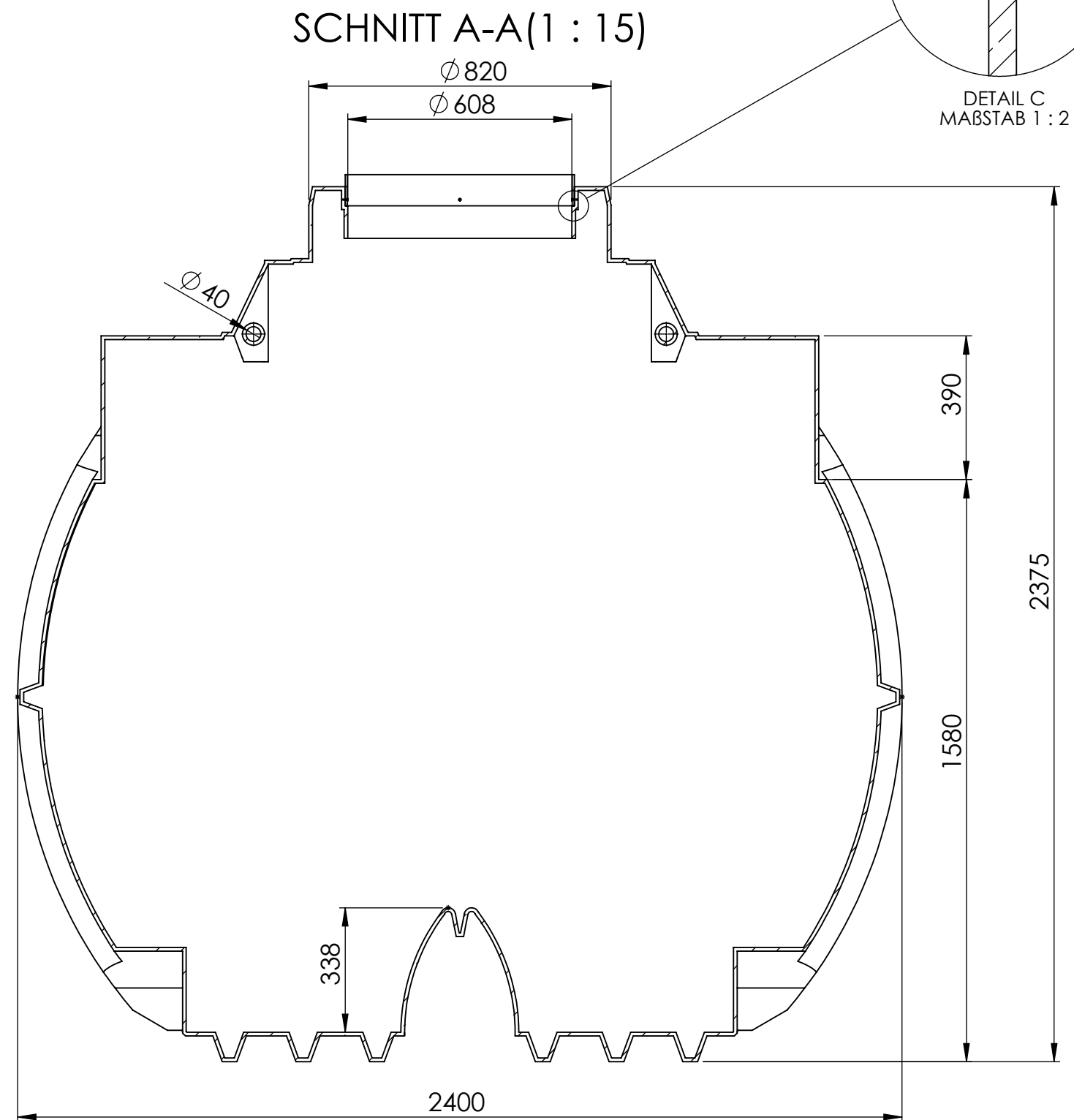
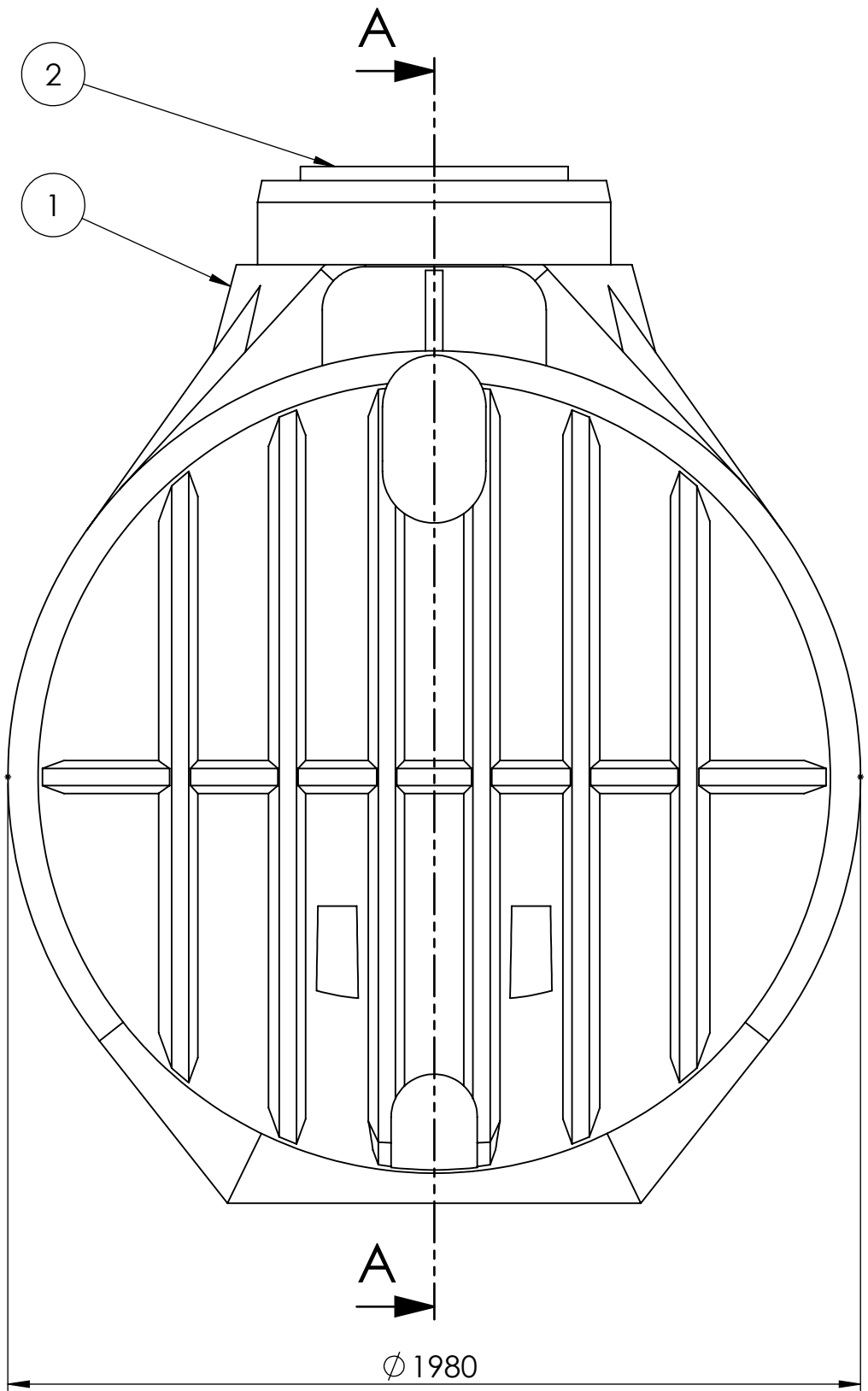

Werkzeugform Optimierung (neue Werkzeuggeometrie)	SW2014	002		F.Trende	11.08.14			
Werkstoffänderung	SW2012	001		F.Trende	12.06.12	J.Gramke	12.06.12	
frei für Vorserie	SW2010	000						
Änderungsindex/Planquadrat/Änderungsbeschreibung State or revision/grid square/Revision text	CAD	ZGS	Auftrags-Nr. order no.	Bearb./auth. Datum/date	Pruef./check Datum/date	Norm./stand. Datum/date		
Werkstoff (Endzustand) material (final condition) siehe Stückliste	Oberfläche/surface (mm ²)		48976793.01	Datum/date	Name/name			
	Farbe/color			Bearb./auth.	04.08.10	F.Trende		
	Oberflächenbeschichtung			Pruef./check	-	-		
	Oberfl. ang./surf. texture	DIN EN ISO 1302		Norm./stand.	-	-		
	Masse/mass (kg)		235.00	Freig./rel.	31.12.2098	-		
Allg.Toleranzen/gen. tolerances DIN ISO 16901 160A	Tolerierung/tolerancing DIN 7168		CAD Solid Works	ZGS 002	Aufr.-Nr./order no. -			
 Köver GmbH & CoKG Schutzvermerk nach DIN ISO 16016 beachten! Refer to protection notice DIN ISO 16016!	Massstab/scale 1:20	Benennung/title Atlantis 5300L ohne Trennwand						
	Kundenzeichnung/customer drawing					Datum/date		
	Format/size	Blatt/sheet	Sach-Nr./basic number		35.4900.0000			
Keine Änderungen ohne Zustimmung der federführenden Konstruktion. / Any alternations are subject to the approval of the design department.								