

Stücklistentabelle					
Pos	Standard /MENGE	Bauteil Nr.	Benennung	Revisionsstand	Material
1	1	35.6500.0000	Atlantis 7000L o.A. Erdspeicher	002	LLDPE
2	1	65.0000.0001	Adapterring	000	PE
3	4	74.5000.0670	Holzschraube Seko A2 4x20-z	000	A2

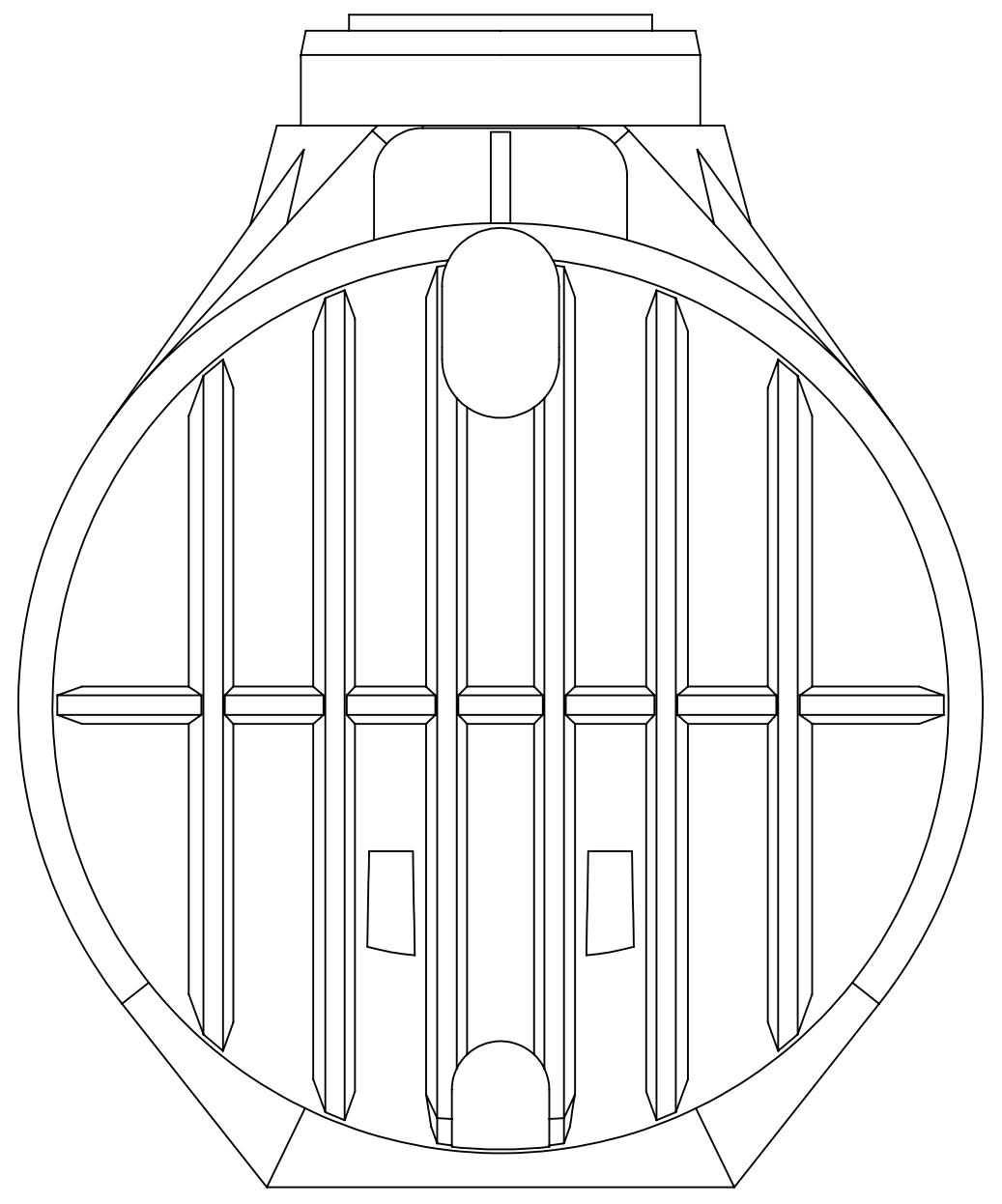
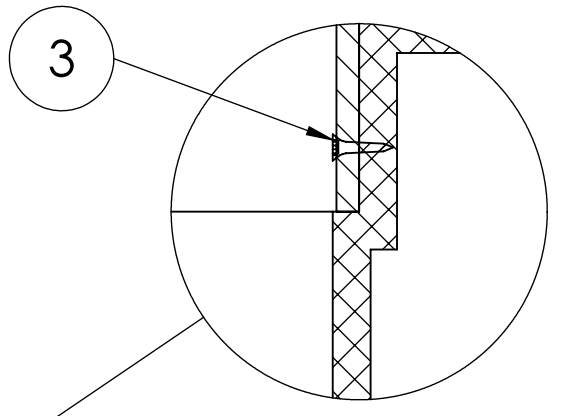
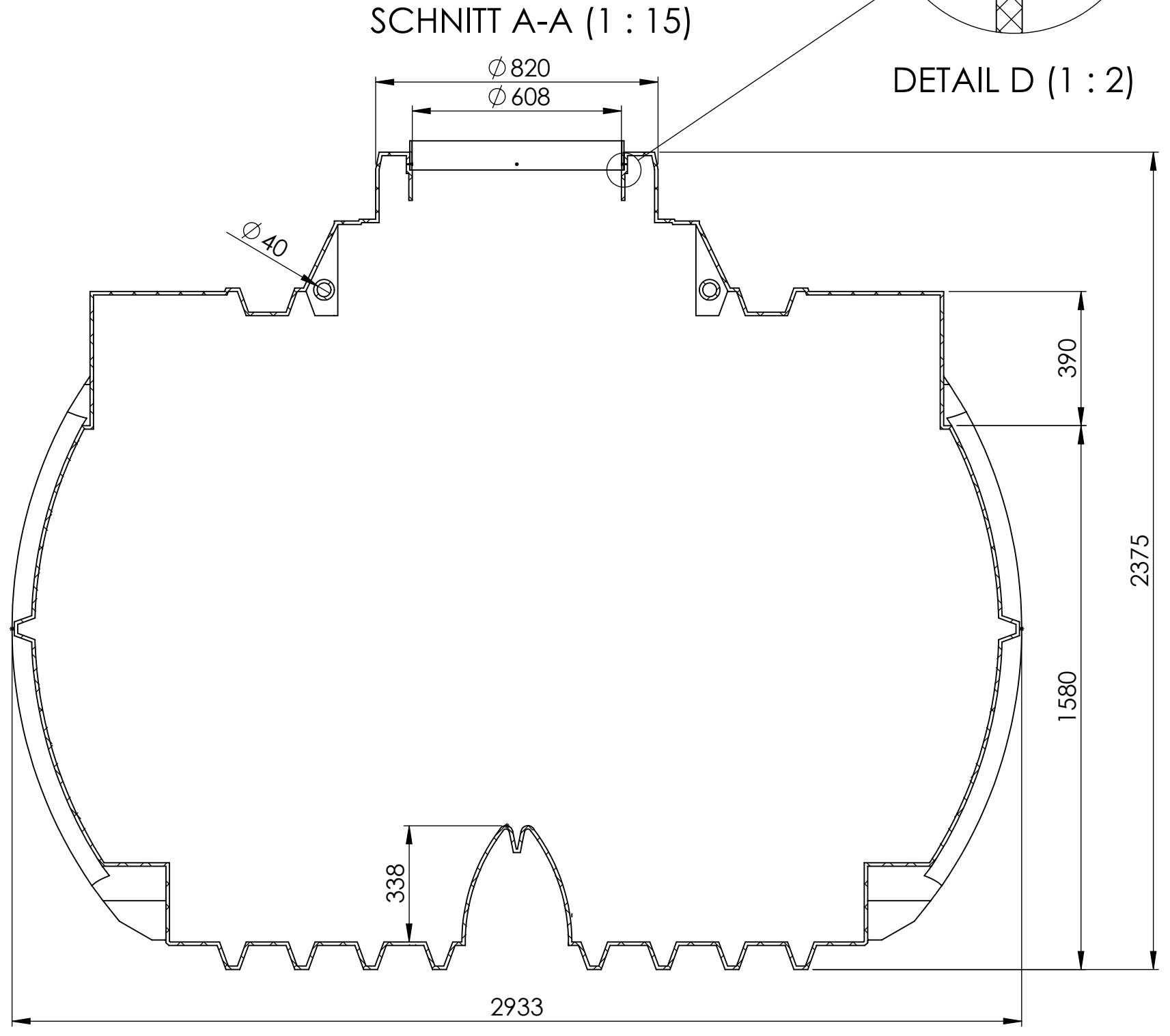
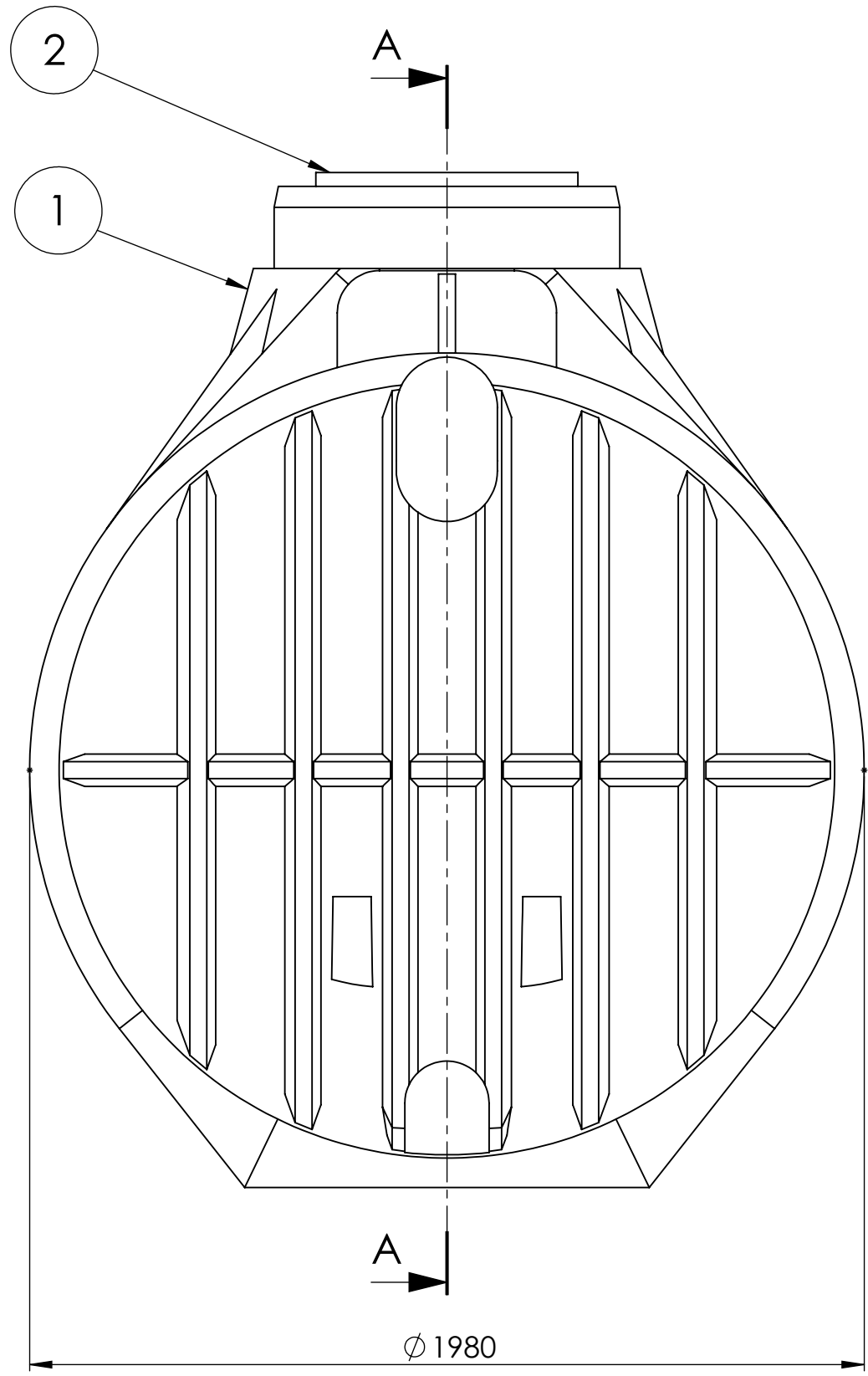

Werkzeugform Optimierung (neue Werkzeuggeometrie)	SW2014	002		F.Trende	11.08.14	
Gewicht 220kg --> 240kg erhöht	SW2012	001		F.Trende	25.07.12	J.Gramke
frei für Vorserie	SW2008	000				
Änderungsindex/Planquadrat/Änderungsbeschreibung State or revision/grid square/Revision text	CAD	ZGS	Auftrags-Nr. order no.	Bearb./auth. Datum/date	Pruef./check Datum/date	Norm./stand. Datum/date
Werkstoff (Endzustand) material (final condition) siehe Stückliste	Oberfläche/surface (mm ²)		57986455.26	Datum/date	Name/name	
	Farbe/color			Bearb./auth.	12.11.08	F.Trende
	Oberflächenbeschichtung			Pruef./check	-	-
	Oberfl. ang./surf. texture	DIN EN ISO 1302		Norm./stand.	-	-
	Masse/mass (kg)	277.13		Freig./rel.	-	-
Allg.Toleranzen/gen. tolerances DIN ISO 16901 160A	Tolerierung/tolerancing DIN 7168	CAD Solid Works	ZGS	002	Auftr.-Nr./order no. -	
 Köver GmbH & CoKG Schutzvermerk nach DIN ISO 16016 beachten! Refer to protection notice DIN ISO 16016!	Massstab/scale 1:20	Benennung/title Atlantis 7000L o.A. Erdspeicher				
	Kundenzeichnung/customer drawing			Datum/date		
	Format/size A2	Blatt/sheet 1	Sach-Nr./basic number 35.6500.0000			
Keine Änderungen ohne Zustimmung der federführenden Konstruktion. / Any alternations are subject to the approval of the design department.						